

X-Block[®]

Installation ideas

X-Block[®] installation at trimmer with 12 cutters

1 X-Block[®] is used for 12 cutters

Compression from 2.5 bar in home position to 4.5 bar at end stroke

Cylinder diameter 80 mm

Stroke 80 mm

95 cycles/minute

Load 45 Kg

Tank volume 0.4 litre

X-Block[®] 2.5 Bar

System 4.5 Bar

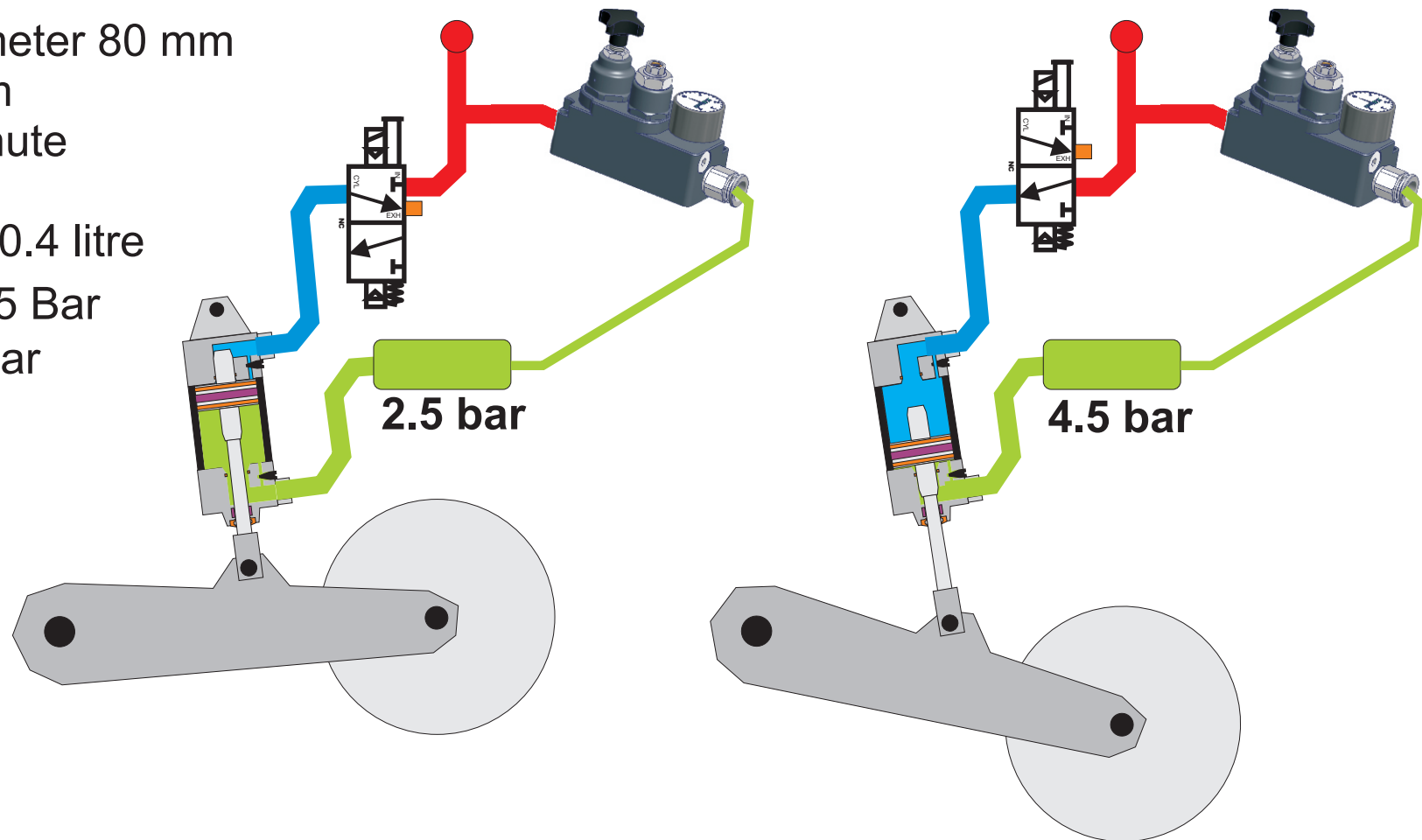

X-Block[®] installation

full clamping force at end position

